



DP3L1-224 series
Open loop stepping driver

User manual

Wuxi Xinje Electric Co., Ltd.

Data No. D3C10 20230214EN 1.0

Basic description

- ◆ Thank you for purchasing Xinje DP3L1 series stepping driver. Please read this product manual carefully before operating.
- ◆ The manual mainly provides the user with relevant guidance and instructions for the correct use and maintenance of the step driver. The manual involves the function, use method, installation and maintenance of the step driver.
- ◆ The contents described in the manual are only applicable to Xinje's DP3L1 series stepping driver products.

Notice to user

This manual is applicable to the following personnel:

- ◆ The installation personnel of stepper driver
- ◆ Engineering and technical personnel (electrical engineers, electrical operators, etc.)
- ◆ The designer

Before operating or debugging the stepper driver, the above personnel should carefully read the safety precautions section of this manual.

Statement of responsibility

- ◆ Although the contents of the manual have been carefully checked, errors are inevitable and we can not guarantee that they are completely consistent.
- ◆ We will always check the contents of the manual and make corrections in subsequent versions. We welcome your comments.
- ◆ The contents described in the manual are subject to change without prior notice.

Contact us

If you have any questions about the use of this product, please contact the agent and office that purchased the product, or contact Xinje company directly.

- ◆ Tel: 400-885-0136
- ◆ Address: No.816, Jianzhu West Road, Binhu District, Wuxi City, Jiangsu Province, China
- ◆ Postcode: 214072
- ◆ Website: www.xinje.com

WUXI XINJE ELECTRIC CO., LTD. Copyright

Without explicit written permission, this information and its contents shall not be copied, transmitted or used. Violators shall be liable for the losses caused. All rights provided in patent license and registration including utility module or design are reserved.

April 2022

Catalog

1. PRODUCT INTRODUCTION	1
1-1. NAMING RULE	1
1-2. PERFORMANCE	1
1-3. APPLICATION FIELD	1
1-4. ELECTRIC FEATURES	2
1-5. SAFETY PRECAUTIONS	2
2. INSTALLATION AND WIRING	3
2-1. INSTALLATION	3
2-1-1 <i>Outline dimension</i>	3
2-1-2 <i>Installation environment</i>	3
2-2. WIRING	4
2-2-1 <i>Typical wiring diagram</i>	4
2-2-2 <i>Wiring notice</i>	5
3. DRIVER INTERFACE	6
3-1. CONTROL SIGNAL INTERFACE	6
3-1-1 <i>Function</i>	6
3-1-2 <i>Control signal circuit</i>	7
3-2. STRONG ELECTRICITY INTERFACE	8
3-2-1 <i>Function</i>	8
3-2-2 <i>Power supply requirements</i>	8
4. DIP SWITCH	9
4-1. PUL MODE (SW10 OFF) CURRENT SUBDIVISION SETTING	10
4-1-1 <i>Working (Dynamic) current setting</i>	10
4-1-2 <i>Static current setting (auto half current)</i>	10
4-1-3 <i>PUL subdivision</i>	10
4-1-4 <i>Command filter time</i>	11
4-2. IO MODE (SW10 ON) SUBDIVISION SETTING	11
4-2-1 <i>Acc/dec setting</i>	11
4-2-2 <i>Speed subdivision setting</i>	11
5. PROTECTION FUNCTION	12
6. COMMON TROUBLESHOOTING	13

1.Product introduction

1-1. Naming rule

DP3L1 - 22 4

① ② ③

- ①: DP3L1 series open loop stepping driver
- ②: Driver output maximum peak current 2.2A
- ③: The maximum supply voltage of the driver is 40VDC

1-2. Performance

- The performance of the new control algorithm is significantly improved, and the torque of medium and high speed is 10-50% higher than that of the original product.
- The motor performance is improved and the temperature rise is reduced.
- It can drive 4, 6, 8-wire two-phase stepping motor.
- 3-digit switch, 8-gear current can be set.
- 4-digit switch, adjustable 16 gears subdivision.IO type can set 16-gear speed.
- Automatic power on and self-tuning function.
- The PUL mode has the function of automatically halving the current when it is still, and the IO mode has the function of adjusting the gears of high and low acceleration and deceleration, and the dial code is optional.
- The pulse response frequency is 150kHz for 5/24V signal.
- With over-current, over-voltage, short circuit and other protection functions.
- External alarm output, maximum output current 50mA, withstand voltage 24VDC.

1-3. Application field

The PUL mode of DP3L1-224 is applicable to various small and medium-sized automatic equipment and instruments, such as pneumatic marking machine, labeling machine, word cutting machine, laser marking machine, plotter, small engraving machine, CNC machine tool, holding device, etc.

IO mode is a special type of motion control driver for external speed regulation, which has the performance of dialing speed regulation, stable start, uniform speed, etc., and is widely used in conveying equipment, such as: dock, PCB feeder, etc.

1-4. Electric features

Item	DP3L1-224
Input power supply (VDC)	20-40
Output peak current (A)	0.4-2.2
Matched motor (base)	42
Outline dimension (mm)	80*21.3*55
Step pulse frequency (Hz)	150K
Control signal input voltage (VDC)	24V/5V
Working temperature	-10°C~50°C
Storage temperature	-20°C~65°C
Humidity	40%~90% RH (No condensation or water droplets)
Vibration	5.9m/s ² Max

1-5. Safety precautions

- (1) The drive must be installed and operated by professional technicians!
- (2) The input voltage of the driver must meet the technical requirements!
- (3) It is strictly forbidden to plug the strong current terminal of the driver when the power is on. When the motor stops, there is still a large current flowing through the coil. Plug the strong current terminal will produce a huge instantaneous induced electromotive force, which will burn the driver!
- (4) Before power on, please ensure the correctness and firmness of power cable, motor cable and signal cable connection!
- (5) Avoid electromagnetic interference!

2. Installation and wiring

2-1. Installation

2-1-1 Outline dimension

- DP3L1-224

Unit: mm

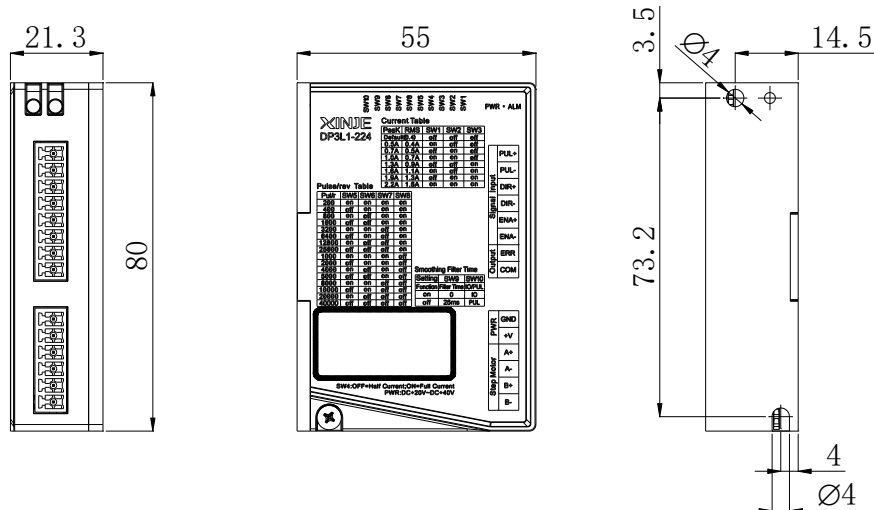

2-1-2 Installation environment

The reliable working temperature of the driver is usually within 60°C and that of the motor is within 80°C. To ensure that the driver works within the reliable working temperature range, the driver should be installed in the electric cabinet with good ventilation and proper protection. If necessary, a fan should be installed near the driver for forced heat dissipation. Avoid being used in dust, oil mist, corrosive gas, high humidity and strong vibration.

2-2. Wiring

2-2-1 Typical wiring diagram

- PUL mode (SW10 set to OFF)

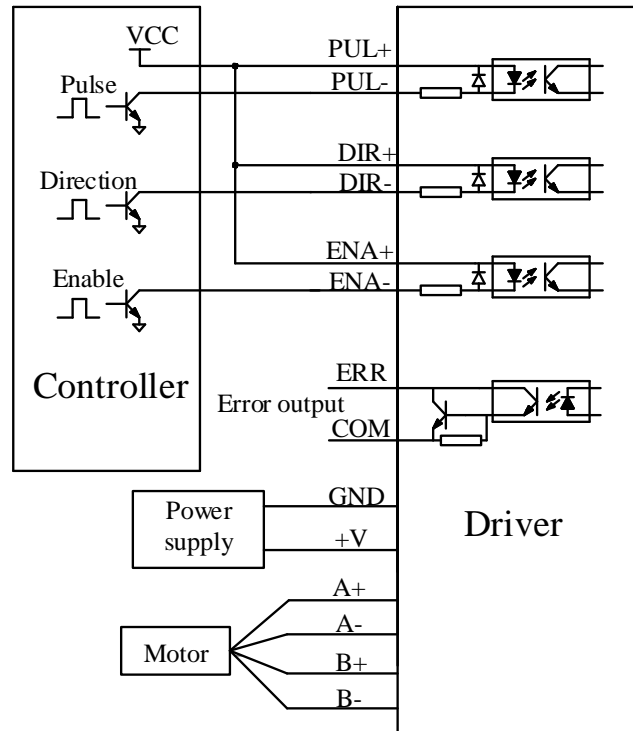

- IO mode (SW10 set to ON)

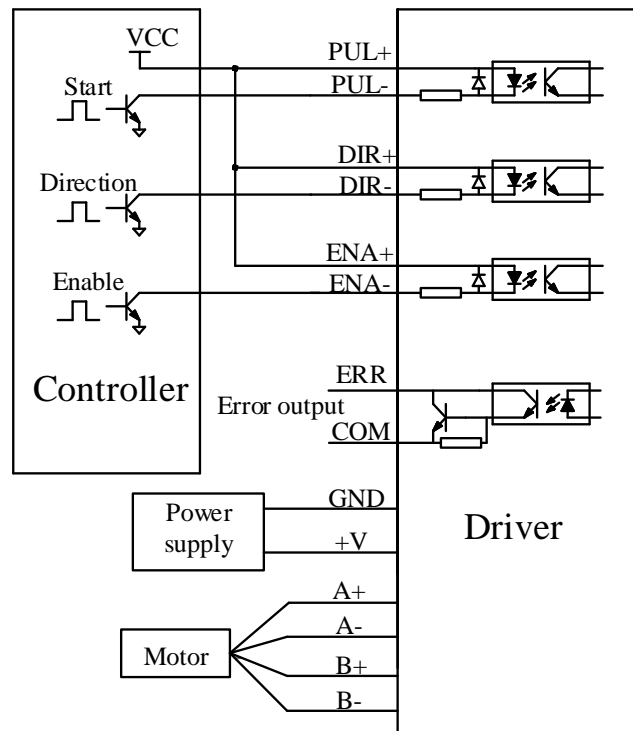

2-2-2 Wiring notice

(1) In order to prevent the driver from being disturbed, it is recommended to use twisted pair shielded wire for the control signal, and the shield layer is short-circuited with the ground wire. Except for special requirements, the shield wire of the control signal cable is grounded at one end: the upper computer end of the shield wire is grounded, and the driver end of the shield wire is suspended.

Note: The same machine is only allowed to be grounded at the same point. If it is not the real grounding wire, the interference may be serious. At this time, the shielding layer is not connected.

(2) Pulse and direction signal wires or starting and direction signal wires and motor wires are not allowed to be tied together side by side. It is better to separate them at least 10 cm or more, otherwise electric interference with pulse direction signals will easily lead to inaccurate motor positioning, system instability and other faults.

(3) If one power supply is used for multiple drives, parallel connection shall be adopted at the power supply, and chain connection from one power supply to another is not allowed.

(4) It is forbidden to connect the wire head to the terminal after tinning, otherwise the terminal may be damaged due to overheating due to increased contact resistance.

(5) The wiring head shall not be exposed outside the terminal to prevent accidental short circuit and damage to the driver.

3. Driver interface

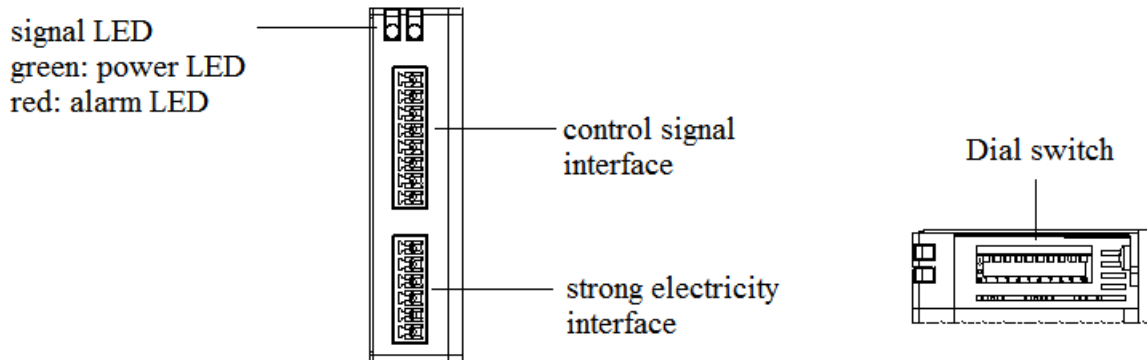

3-1. Control signal interface

3-1-1 Function

Signal	Function	Explanation
PUL+	Pulse control signal	In PUL mode, it is used as a pulse signal, and the rising edge is effective, supporting 5/24VDC.
PUL-		It is used as a starting signal in IO mode. The high level is effective and supports 5/24VDC.
DIR+	Direction control signal	High/low level signal corresponds to two directions of motor operation.
DIR-		The initial running direction of the motor depends on the wiring of the motor. Interchange of any phase can change the initial running direction of the motor.
ENA+	Enable /release signal	It is used to release the motor. When the enable signal is on, the driver will cut off the current of each phase of the motor and be in a free state, and the step pulse will not be responded. At this time, the heating and temperature rise of the drive and motor will be reduced. When not in use, hang the motor release signal terminal in the air.
ENA-		
ERR	Alarm output signal	Alarm output, maximum saturation output 50mA, maximum 24VDC, alarm output terminal outputs high level.
COM		

3-1-2 Control signal circuit

DP3L1-224 allows receiving signals from open collector and PNP output circuits. There are two kinds of connection methods: common cathode and common anode. Now taking NPN output as an example, the schematic diagram of interface circuit is as follows:

- PUL mode (SW10 set to OFF)

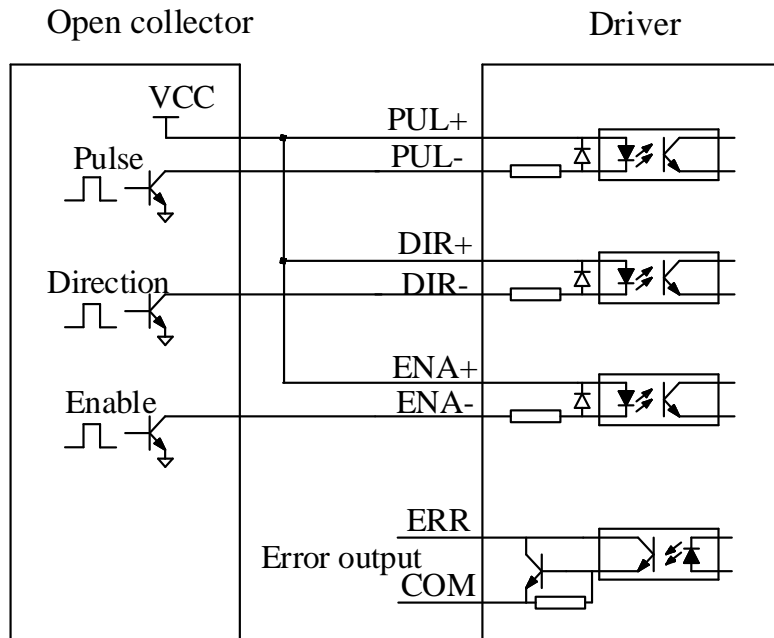

- IO mode (SW10 set to ON)

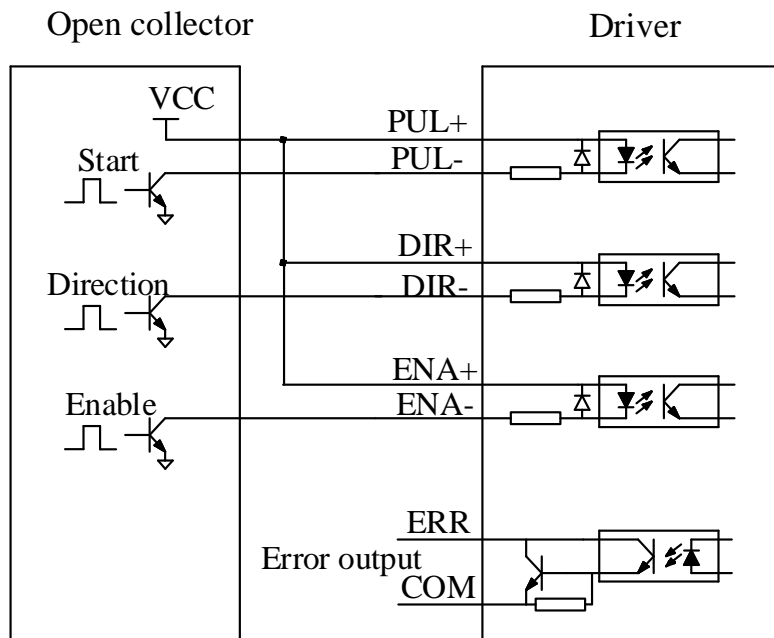

Note:

VCC supported 5/24VDC.

3-2. Strong electricity interface

3-2-1 Function

Interface	Function	Explanation
GND	DC power supply ground	DC power supply ground
V+	Positive pole of DC power supply	Support DC20~40V
A+, A-	Motor phase A coil	Exchange A+, A-, can change the motor operation direction
B+, B-	Motor phase B coil	Exchange B+, B-, can change the motor operation direction

Note:

Before power supply, select the appropriate power supply, and then power on if the specification ensures that the wiring is correct.

When using DC power supply, there is no protection inside the circuit, so it is necessary to distinguish the positive and negative pole wiring.

3-2-2 Power supply requirements

The power supply voltage can work normally within the calibration range, and the driver is preferably powered by low-voltage DC power supply. 20-40 DC power supply is recommended to avoid grid fluctuations exceeding the operating range of the driver voltage.

Note:

- (1) Do not reverse the power supply voltage!
- (2) Do not exceed the working range of the power supply to ensure the normal operation of the driver.
- (3) The power supply should be low voltage DC power supply, and the output capacity of the power supply should be greater than 60% of the set current of the driver.
- (4) In order to reduce the cost, two or three drives can share one power supply, but the power supply should be large enough.

4. DIP switch

DP3L1-224 driver adopts 8-digit DIP switch to set subdivision precision, dynamic current and static half current. Detailed description is as follows:

PUL mode

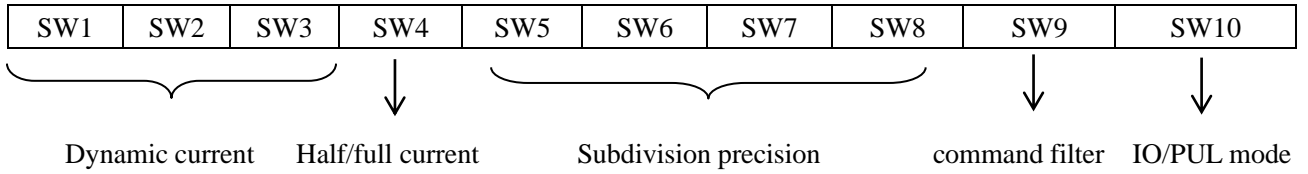

IO mode

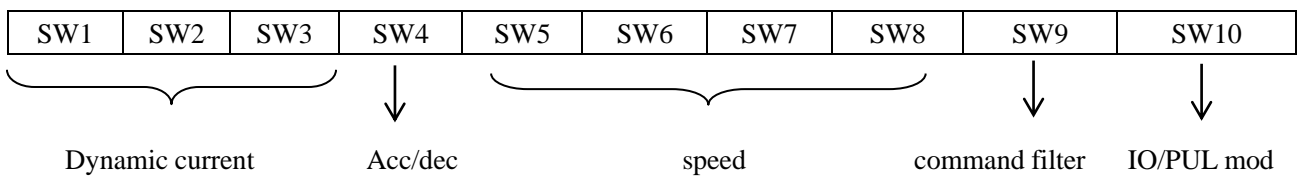

4-1. PUL mode (SW10 OFF) current subdivision setting

4-1-1 Working (Dynamic) current setting

DP3L1-224 dial switch current

Output peak current	Output mean current	SW1	SW2	SW3
Default(0.4A)		Off	Off	Off
0.5A	0.4A	On	Off	Off
0.7A	0.5A	Off	On	Off
1.0A	0.7A	On	On	Off
1.3A	0.9A	Off	Off	On
1.6A	1.1A	On	Off	On
1.9A	1.3A	Off	On	On
2.2A	1.6A	On	On	On

4-1-2 Static current setting (auto half current)

SW4 set static current:

SW4 = off: (default) after the driver stops receiving the pulse for about 0.4 seconds, the output current is 50% of the peak value (setting half current can reduce the heating of the driver and motor in some applications).

SW4 = on: the output current of the driver is 100% of the peak value when the motor is static.

4-1-3 PUL subdivision

Steps	SW5	SW6	SW7	SW8
200	On	On	On	On
400	Off	On	On	On
800	On	Off	On	On
1600	Off	Off	On	On
3200	On	On	Off	On
6400	Off	On	Off	On
12800	On	Off	Off	On
25600	Off	Off	Off	On
1000	On	On	On	Off
2000	Off	On	On	Off
4000	On	Off	On	Off
5000	Off	Off	On	Off
8000	On	On	Off	Off
10000	Off	On	Off	Off
20000	On	Off	Off	Off
40000	Off	Off	Off	Off

4-1-4 Command filter time

SW9 filter instruction dial switch:

SW9=on: instruction filtering time OFF.

SW9=off: instruction filtering time ON, filtering time 25ms.

The instruction filtering function is only effective in the PUL mode and is used to execute pulse instructions more smoothly.

Note: By default, SW9 of the driver is OFF.

4-2. IO mode (SW10 ON) subdivision setting

4-2-1 Acc/dec setting

SW4 set high and low acceleration and deceleration:

SW4=off: acceleration/deceleration gear 1, low acceleration/deceleration.

SW4=on: acceleration gear 2, high acceleration and deceleration.

The acceleration and deceleration should be set by default for different speeds to ensure that the speed under the dial code can run without stagnation.

Note: IO type open-loop stepper driver works in half-flow mode by default.

4-2-2 Speed subdivision setting

Speed rpm/min	SW5	SW6	SW7	SW8
10	On	On	On	On
20	Off	On	On	On
30	On	Off	On	On
50	Off	Off	On	On
60	On	On	Off	On
80	Off	On	Off	On
100	On	Off	Off	On
150	Off	Off	Off	On
200	On	On	On	Off
250	Off	On	On	Off
300	On	Off	On	Off
400	Off	Off	On	Off
500	On	On	Off	Off
600	Off	On	Off	Off
700	On	Off	Off	Off
800	Off	Off	Off	Off

5. Protection function

The green LED is the power indicator. When the driver is powered on, the LED is always on; When the drive is powered off, the LED goes off.

The red LED is the fault indicator. When there is a fault, the indicator will flash continuously, then stop for one second, and then flash continuously; When the fault is cleared by the user, the red LED is always off. The continuous flashing times of red LED represent different fault information, and the specific relationship is shown in the table below.

The alarm output terminal outputs high level

Flashing	Fault	Reason and solution
Flash once	Over current or short circuit	The possible causes of alarm are: wiring error, driver short circuit, electromagnetic interference. Check wiring, power on again, clear the alarm.
Flash 2 times continuously	Over voltage	When the driver voltage exceeds 60VDC, it will enter the overvoltage protection. At this time, it is necessary to reduce the power supply and power on again to clear the alarm.
Flash 4 times continuously	Motor open circuit or poor contact	The motor state is detected when the parameters of the power on motor are self-tuning. During the operation, the motor disconnection and other information are not detected. Check wiring, power on again, clear the alarm

Note:

The overvoltage value of DP3L1-224 is 40VDC.

Since the driver does not have the protection function of positive and negative polarity reverse connection of power supply under DC power supply, please reconfirm that the positive and negative polarity of power supply is correctly connected before power-on.

6. Common troubleshooting

Fault	Reason	Solution
The power light doesn't work	Power supply system error	Check the power supply circuit
	Low supply voltage	Increase the power supply voltage
The motor doesn't work	The current setting is too small	Set suitable current
	The subdivision is too small in PUL mode	Set suitable subdivision
	Acceleration and deceleration time is too short in IO mode	Set suitable acc/dec time
	Protection circuit action	Power on again
	Release signal is low	Do not connect this signal
	Not power on	Power on again
	Motor wiring error	Check the wiring
Motor direction is error	No pulse signal input	Adjust the pulse width and signal voltage
	Line failure	Check the circuit
Alarm light is on	Phase order is reversed	Interchange the wiring of any phase
	Motor cable connection error	Wiring again
	Voltage too high or too low	Adjust the power supply voltage
Motor torque is small	Motor or driver damaged	Check the motor and driver
	Acceleration is too fast	Decrease the acceleration value
	The model selection is not suitable	Select the model again



XINJE

WUXI XINJE ELECTRIC CO., LTD.

No.816, Jianzhu West Road, Binhu District, Wuxi City, Jiangsu Province, China

Tel: 400-885-0136

Fax: (510) 85111290

www.xinje.com